

HONDA

INSTALLATION INSTRUCTIONS

Accessory
ALUMINUM SKID PLATES
 P/N 08P73-HL4-AK0

Application
**SXS1000M3P/M3D/
 M3LS/M5P/M5D/M5LS/
 M3DF/M3DT/M5DT/M5DF**

Publication No.
MII 17762
 Issue Date
April 2022

PARTS LIST

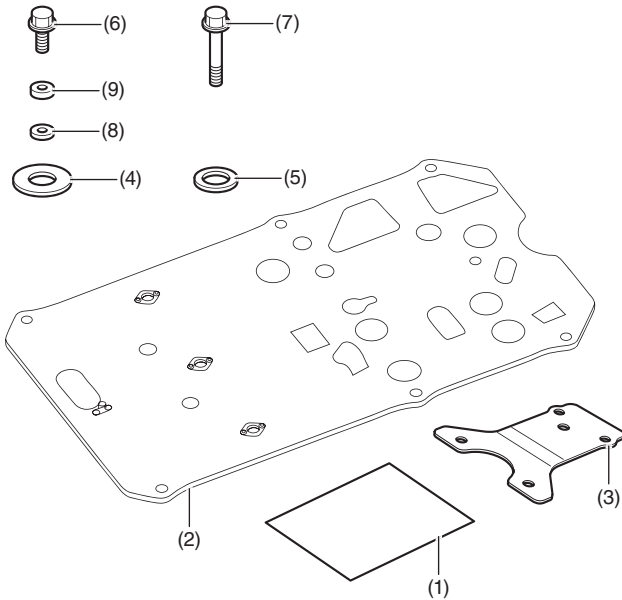

No.	Description	Qty
(1)	Installation Instructions URL	1
(2)	Middle skid plate	1
(3)	Rear skid plate	1
(4)	Washer (large)	15
(5)	Washer (small)	1
(6)	6 mm flange bolt (short)	15
(7)	6 mm flange bolt (long)	1
(8)	Collar (thin)	12
(9)	Collar (thick)	3

TOOLS AND SUPPLIES REQUIRED

Socket (10 mm)
 Ratchet
 Torque wrench

TORQUE CHART

Tighten all screws, bolts, and nuts to their specified torque values. Refer to the Service Manual for the torque values of the removed parts.

Item	N-m	kgf-m	lbf-ft
6 mm flange bolt	16	1.6	12

INSTALLATION

⚠ CAUTION: To prevent burns, allow the engine, exhaust system, radiator, etc., to cool before installing the accessory.

1. Remove the front skid plate as shown.

<Under side>

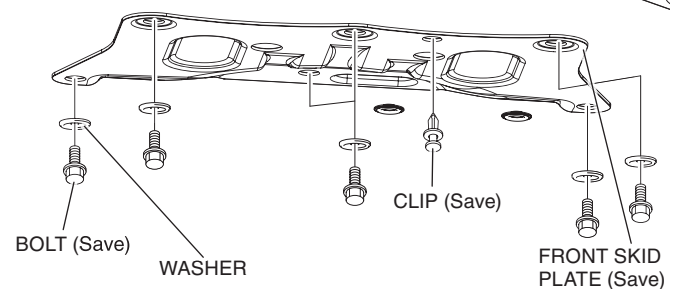
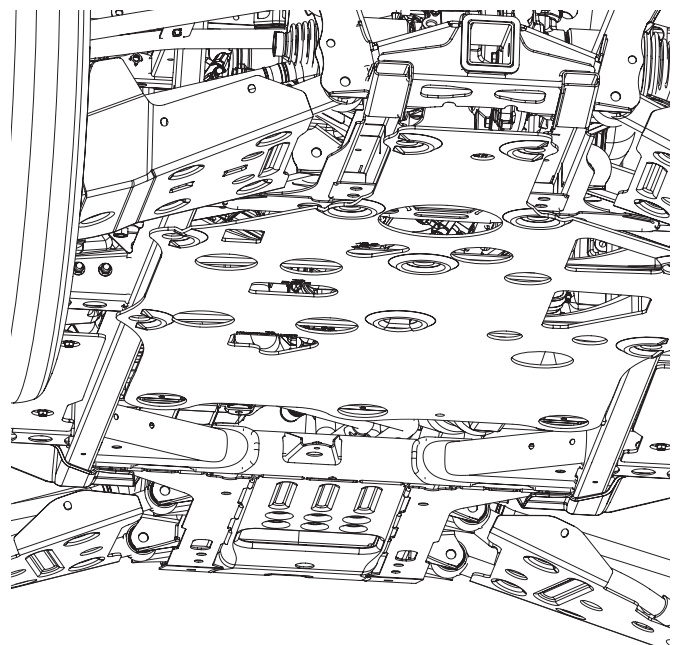

2. Remove the parts as shown.

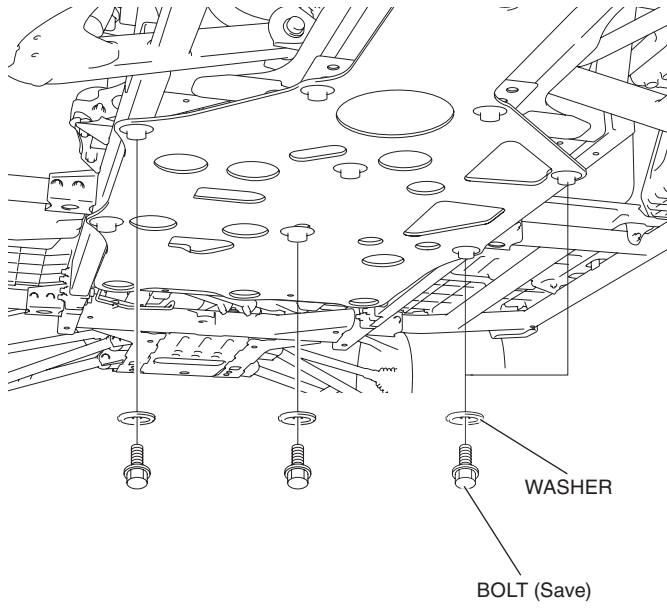

3. Remove the middle skid plate as shown.

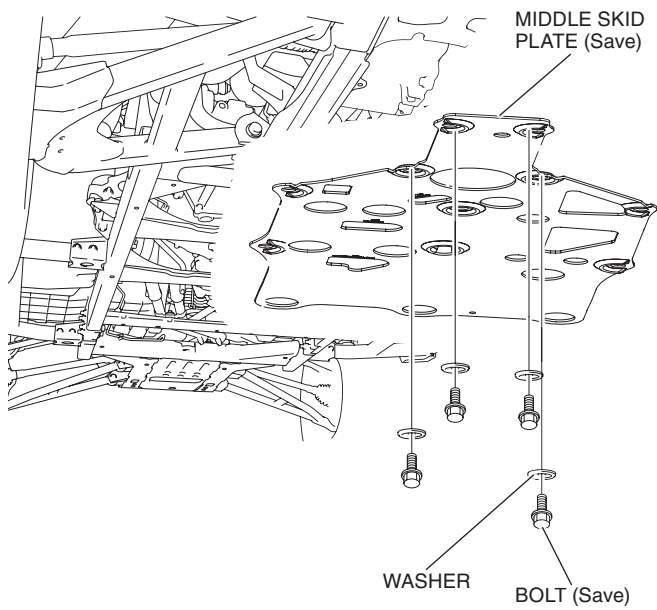

4. Install the rear skid plate as shown.

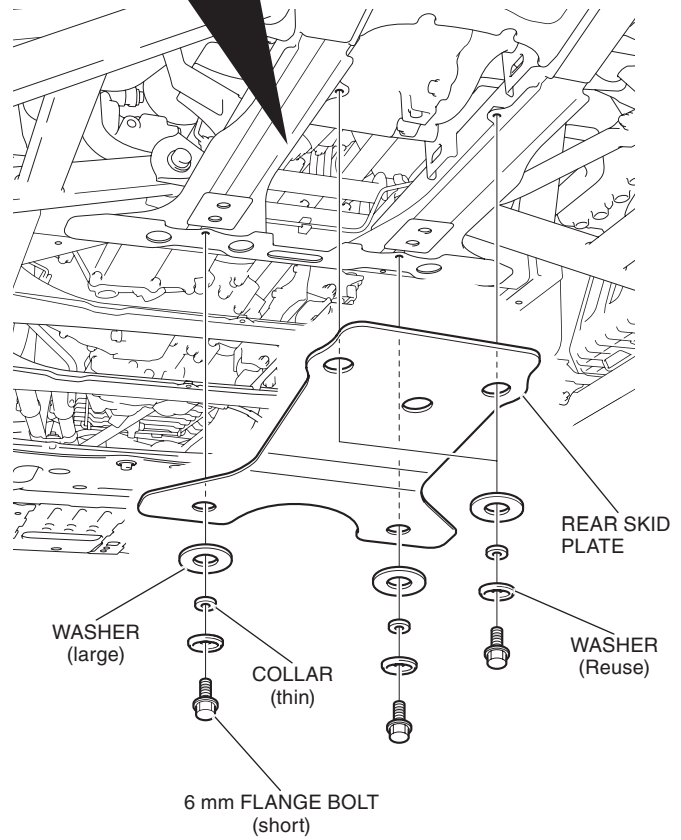
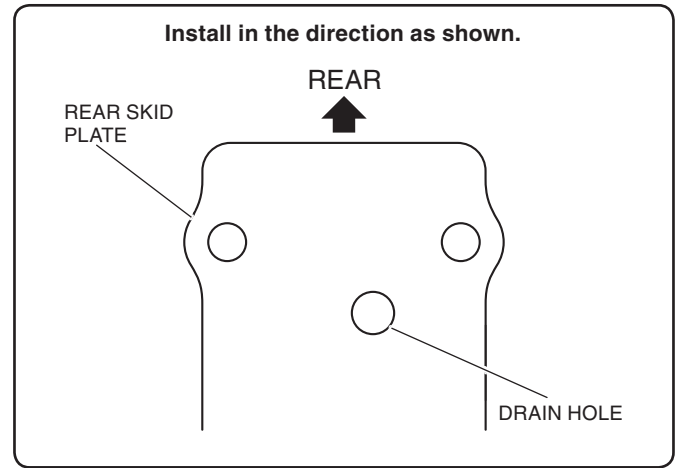

5. Loosely install the accessory middle skid plate as shown:

- First, loosely install the center bolt, washer, collar, and large washer to the vehicle.
- Next, slip the accessory middle skidplate keyhole over the center bolt/washer and hang the skidplate from the center bolt/washer.
- Loosely install the remaining hardware at the positions shown.

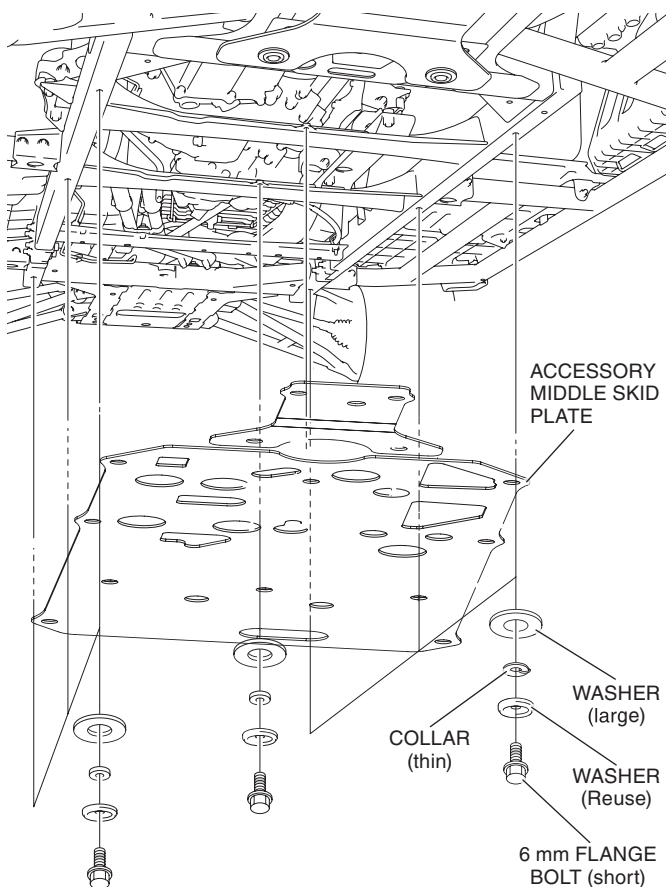

6. Loosely install the hardware at the positions shown.

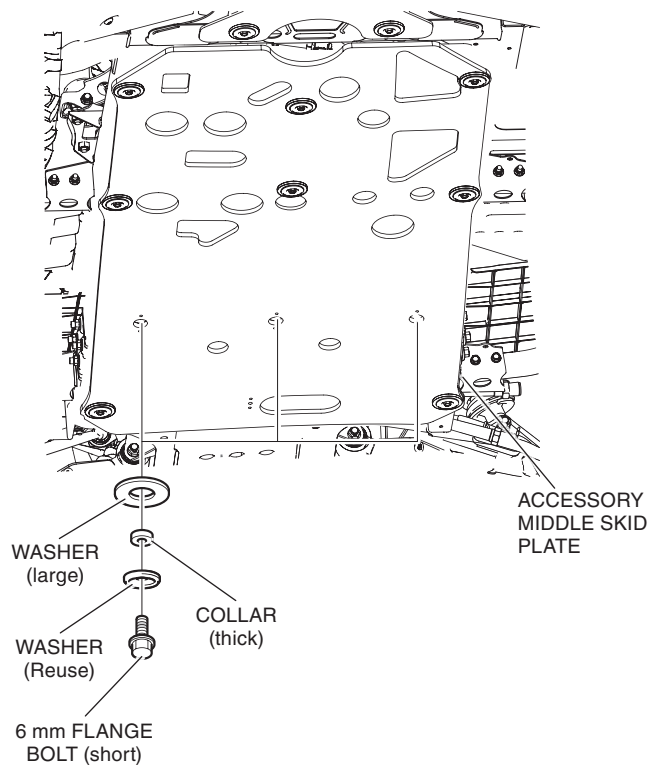

7. Install the hardware at the position shown.

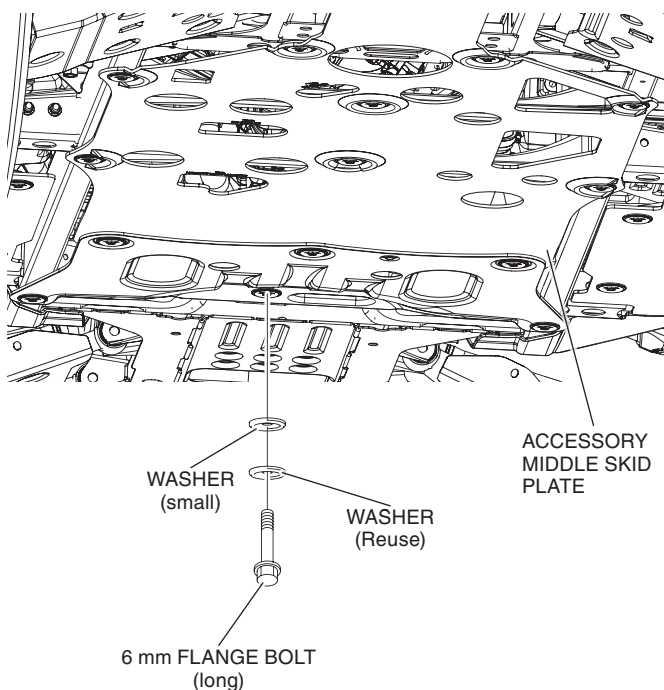

8. Tighten the loosely installed hardware to the values specified in the Torque Chart.